

Texas Instruments

Home Computer

Accessory

Telephone Coupler (Modem)

Model No. PHP1600

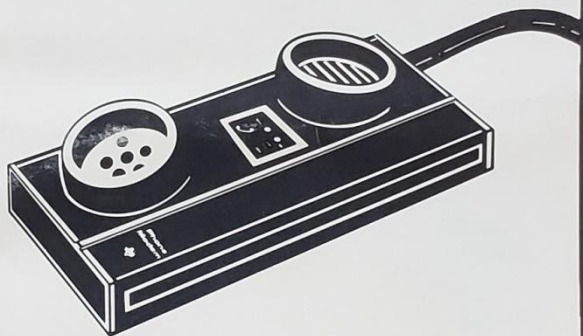

Retrocomputing

Enables your TI Home Computer to communicate via a standard telephone. With a TI Telephone Coupler (Modem) and the TI RS232 Interface (sold separately), your Home Computer can communicate with similarly equipped computers. You can send and receive messages and data, transfer programs between Home Computers, and access information from consumer data services you subscribe to. See the owner's manual for the TI RS232 Interface for details of the Home Computer's communicating capabilities.



In order for information to be sent or received via the telephone system, the data output from your computer must be converted to a different form.

The term "modem" is a combination of two words: "modulator" and "demodulator". The modulator part of the modem converts information to a form that can be sent through the telephone system and the demodulator converts information received through a telephone to a form that can be used by a computer. The features of the TI Telephone Coupler (Modem) include:

- Compatibility with the Bell 103 type modems.
- A built-in cable with 25-pin, male connector for connection to the TI RS232 Interface.
- Data transfer rates up to 300 Baud (300 Baud means 300 bits of data are transferred per second).
- Switch-selectable HALF and FULL-duplex operation.
- A TEST mode for verifying proper operation of the modem.
- Switch-selectable ORIGINATE and ANSWER modes.
- A UL-listed and CSA-approved low-voltage AC adapter to power the modem.

IMPORTANT

The TI RS232 Interface is required for the proper operation of the TI Telephone Coupler (Modem). This unit is sold separately.

Installation

First, unpack the TI Telephone Coupler (Modem) and its AC adapter. To hook up your modem, slide the "Originate-Off-Answer" switch to the "Off" position, push the power connector into the receptacle at the end of the modem. as shown in Figure 1, and plug the AC adapter into a standard 115-volt outlet.

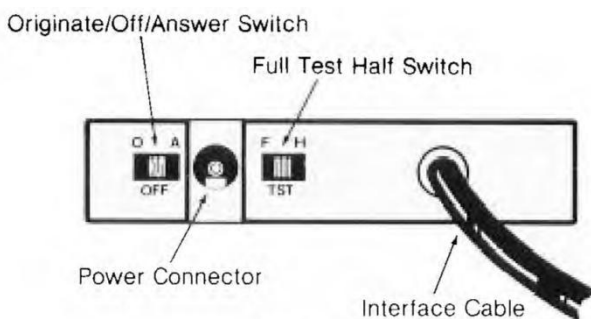

Figure 1

Next connect the modem cable to the TI RS232 Interface. Slide the switch to the Originate (O) or Answer (A) position and check to see that the POWER indicator lamp is lighted. Before beginning operation, you should test your TI Telephone Coupler to be sure it is working properly. For the proper procedure, see the Test Mode section of this manual.

Operation

When you are using your computer to access data information services you subscribe to, you will need an RS232 Interface unit and one of the Command Modules designed for this purpose. See the module manual for operational information.

To communicate with another TI Home Computer (or other computer), follow these procedures. One modem must be in the ORIGINATE mode and the other in the ANSWER mode. Prior to establishing communications between computers, you and the person at the remote location mutually decide which mode of operation each of you will use.

Then, you should select the FULL-DUPLEX or HALF-DUPLEX mode. Normally you only use the FULL-DUPLEX mode unless an application program or Command Module requires the HALF-DUPLEX mode. If you decide to use the ORIGINATE mode, slide the "Originate-Off-Answer" switch to the Originate position. The other person selects the ANSWER mode and connects their phone to a modem. You should then hear an answering tone from your earpiece.

When you hear this tone, push your telephone handset into the acoustic muffs with the cord toward the RS232 cable. Make sure that the phone handset fits snugly in the muffs. When the modem is ready to communicate, the READY indicator will light and you may begin transmitting information.

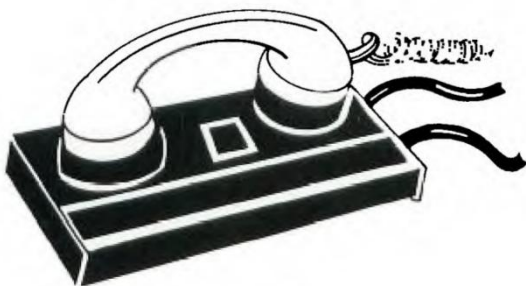

Figure 2

If you have agreed to use the ANSWER mode, first, slide the switch to the Answer position, and then place the handset in the acoustic muffs just as you did when using the modem in the ORIGINATE mode. When your modem is in the ANSWER mode, you will hear a tone whether or not the READY indicator is on. When The READY indicator turns on, you may proceed with normal communications.

When the information transfer has been completed, simply slide the switch to the Off position and hang up the telephone.

The TEST Mode

As mentioned previously, your TI Telephone Coupler has a TEST mode which enables you to verify that the modem is working properly. The test procedure consists of the following steps:

1. Set the "Full-Test-Half" switch to the middle or "Test" position.
 2. Slide the "Originate-Off-Answer" switch to the Originate position. You should hear a continuous tone from the speaker muff, if not, the modem is defective (see "In Case of Difficulty").
-

-
3. Select TI Basic from the Master Selection List.
 4. Enter the following program:

```
100 REM – TEST MODE –  
110 OPEN #1: "RS232.EC.LF", FIXED 1  
120 CALL KEY (0,KEY,STATUS}  
130 IF STATUS = 0 THEN 120  
140 PRINT #1: CHR$(KEY)  
150 INPUT #1: A$  
160 PRINT A$  
170 GOTO 120
```

Then type RUN and press ENTER to start the test program.

5. Dial a single digit on the telephone and push the handset into the muffs as before. Dialing one digit eliminates the dial tone and obtains a quiet line. Since the line will remain quiet for only a short time. it may be necessary to dial another digit every half-minute or so to prevent the dial tone from interfering with the test. An alternative method which will keep the phone line quiet for a longer period of time is to dial another telephone number and ask the person answering to cover the mouthpiece. This will keep background or room noise from interfering with the test.

To test the ORIGINATE mode, proceed as indicated:

6. Wait for a READY indication.
7. Press any alphanumeric key on the keyboard of your Home Computer.
8. If the key symbol appears on the TV screen, the ORIGINATE mode is working properly.

Next test the operation of the ANSWER mode:

9. Slide the switch to the answer position. (It is not necessary to move the telephone handset.)
10. Wait for the READY indicator to come on and then press a key.
11. Again check the displayed key symbol.

If the key symbol is not displayed or displayed incorrectly, in either the ORIGINATE or ANSWER modes, see "In Case of Difficulty".

In Case of Difficulty

The problem that occurs most often with a properly connected modem is a poor telephone connection or a noisy telephone line. This can cause errors in the transfer of information or loss of information. Try to obtain a clear, noise-free line by redialing the telephone number. If the TEST mode indicates your TI Telephone Coupler (Modem) is working properly and you are still having trouble, check the following table for other sources of the problem.

TROUBLE	WHAT TO DO
READY Indicator does not come on:	<p>Check to be sure power is on.</p> <p>Check the position of the handset. (see Figure 2)</p> <p>Check the position of the mode switches.</p> <ol style="list-style-type: none">1. When communicating with another computer, one modem must be in the ORIGINATE mode and the other in the ANSWER mode. Usually, you and the person at the other end of the phone line agree on which mode each of you will use prior to beginning communications.2. The TI Telephone Couplers (Modems) must be in either FULL-DUPLEX or HALF-DUPLEX for proper communications. The TEST mode will not work for information transfers.3. If you are using TI BASIC PROGRAMS, the Telephone Couplers (Modems) must be in FULL-DUPLEX mode.

TROUBLE	WHAT TO DO
Garbled Display	<p>4. If you are using a time-sharing service, your Telephone Coupler (Modem) should normally be in the ORIGINATE mode.</p> <p>The modem at the other location must be compatible with yours. Your TI Telephone Coupler (Modem) can communicate with a similar TI unit or with a Bell 103 compatible modem.</p> <p>Check the handset to be sure it is snugly seated in the acoustic muffs. Both your Home Computer and the remote computer must transfer information at the same rate (300 Baud maximum). See the TI RS232 Interface manual for more information on Baud rate.</p> <p>Check the telephone line. If it sounds noisy or weak or you hear voices, dialing sounds, or other tones, redial the telephone number.</p>

Specifications

Size:	25.9 x 11.9 x 5.8 cm
Weight:	0.68 kg
Power:	Supplied by UL-listed, CSA-approved AC adapter with connecting cord.
Modem Compatibility:	Bell 103
Data Interface:	The TI Telephone Coupler (Modem) has a built-in cable which provides connection to the TI RS232 Interface via a 25-pin male connector.

Pin Connections

Pin#	Function	Input/Output
2	Receive Data	Output (to Home Computer)
3	Transmit Data	Input (from Home Computer)
7	Signal Ground	Common
20	Modem Ready	Output

Service Information

If the Telephone Coupler is in warranty, it will be repaired or replaced under the terms of the Limited Warranty. Out-of-warranty units in need of service will be repaired or replaced with reconditioned units (at TI's option), and service rates in effect at the time of return will be charged. Because our Service Facility serves the entire United States, it is not feasible to hold units while providing service estimates. For advance information concerning our flat-rate service charges, please call our toll-free number listed below.

If you have questions concerning repair, please call our Customer Relations Department at 800-858-4565 (toll free within the contiguous United States except Texas) or 800-692-4279 within Texas. The operators at these numbers cannot provide programming assistance.

For questions of a technical nature, you can call 806-741-2663. Please note that this is not a toll-free number, and we cannot accept collect calls.

Exchange Centers

If your TI Telephone Coupler requires service, instead of returning the unit to a service facility for repair or replacement, you may elect to exchange the unit for a factory-reconditioned unit of the same model (or equivalent model specified by TI) by going in person to one of the exchange centers which have been established across the United States. Out-of-warranty exchanges will be charged at the rates in effect at the time of the exchange. Please refer to the enclosed Exchange Service listing, or call the Consumer Relations Department for the location of the nearest exchange center.

Three-Month Limited Warranty

THIS TEXAS INSTRUMENTS TELEPHONE COUPLER (MODEM) WARRANTY EXTENDS TO THE ORIGINAL CONSUMER PURCHASER OF THE ACCESSORY.

WARRANTY DURATION

This Telephone Coupler (Modem) unit is warranted for a period of three (3) months from the date of the original purchase by the consumer.

WARRANTY COVERAGE

This Telephone Coupler (Modem) unit is warranted against defective materials or workmanship. **THIS WARRANTY IS VOID IF THE ACCESSORY HAS BEEN DAMAGED BY ACCIDENT, UNREASONABLE USE, NEGLIGENCE, IMPROPER SERVICE OR OTHER CAUSES NOT ARISING OUT OF DEFECTS IN MATERIALS OR WORKMANSHIP.**

WARRANTY DISCLAIMERS

ANY IMPLIED WARRANTIES ARISING OUT OF THIS SALE, INCLUDING BUT NOT LIMITED TO THE IMPLIED WARRANTIES OF MERCHANTABILITY AND FITNESS FOR A PARTICULAR PURPOSE, ARE LIMITED IN DURATION TO THE ABOVE THREE-MONTH PERIOD. TEXAS INSTRUMENTS SHALL NOT BE LIABLE FOR LOSS OF USE OF THE TI TELEPHONE COUPLER OR OTHER INCIDENTAL OR CONSEQUENTIAL COSTS, EXPENSES, OR DAMAGES INCURRED BY THE CONSUMER OR ANY OTHER USER.

Some states do not allow the exclusion or limitation of implied warranties or consequential damages, so the above limitations or exclusions may not apply to you.

LEGAL REMEDIES

This warranty gives you specific legal rights, and you may also have other rights that vary from state to state.

WARRANTY PERFORMANCE

During the above three-month warranty period, your TI Telephone Coupler (Modem) will be repaired or replaced with a new or reconditioned unit of the same or equivalent model (at TI's option) when the unit is returned by prepaid shipment to a Texas Instruments Service Facility listed below. The repaired or replacement unit will be warranted for three months from date of repair or replacement. Other than the postage requirement, no charge will be made for the repair or replacement of in-warranty units.

Texas Instruments strongly recommends that you insure the unit for value, prior to shipment.

TEXAS INSTRUMENTS CONSUMER SERVICE FACILITY

U.S. Residents

Texas Instruments Service Facility
2303 North University
Lubbock, Texas 79415

Canadian Residents

Geophysical Services Incorporated
41 Shelley Road
Richmond Hill, Ontario, Canada L4C5G4

Consumers in California and Oregon may contact the following Texas Instruments offices for additional assistance or information.

Texas Instruments Consumer Service
831 South Douglas Street
El Segundo, California 90245
(213)973-1803

Texas Instruments Consumer Service
10700 Southwest Beaverton Highway
Park Plaza West
Beaverton, Oregon 97005
(503)643-6758

TEXAS INSTRUMENTS
INCORPORATED
DALLAS, TEXAS